



# *Better Bagger™* **900e**



## **Service Manual**

## CONTENTS

Parts list with reorder numbers.	Page 1
Parts Identification Photographs	Pages 2 - 4
Service Instruction	Pages 5 - 10

The following Parts and Assemblies are replaceable by qualified technicians:

<b>Part or Assembly</b>	<b>Service Description</b>	<b>Part Number</b>
Bag Drive Roller, Lower	1	E900-160-01
Bag Factory		E900-002-01
Bag Factory Connector/Cable Assy	2	E900-192-01
Bag Feed Belt	3	ST-2583
Bag Feed Motor	4	E900-156-01
Blade Drive Belt		ST-2581
Blade Drive Motor	5	E900-155-01
Blade Drive Sensor	6	E900-177-03
Display Board Assy	7	E900-182-01
Encoder Disc	8	E555-150-00
Encoder Sensor	9	E900-177-01
Exit Sensor	10	E900-241-01
Exit Sensor Cable		E900-157-01
Feed Deck	11	E900-034-00
Fuse, Main, External		ST-2341
Heat Adjustment Knob		ST-2726
Heat Adjustment Switch/Cable Assy	12	E900-158-01
Heater (Seal) Wire Repair Kit		E900-224-01
Input Power Module	13	ST-2853
Keypad, Rubber/Membrane Switch	14	E900-154-01
Knife Cam Sensor		E900-177-03
Left Side Cover		E900-090-01
Lower Blade Assy	15	E900-014-00
Magnetic Interlock Switch Assy		E900-176-01
Main Controller Board	16	E900-151-01
Power Cord		ST-484
Power Switch	17	ST-2297
Rear Guide Bar	18	E900-072-01
Right Side Cover		E900-091-01
Roll Bar		E900-062-01
Roll Bar Collars		E900-015-01
Roll Bar Receptacles		E900-101-01
Seal Bar Assembly	19	E900-021-01
Sealer Drive Belt	20	ST-2580
Sealer Drive Motor	21	E900-155-01
Temperature Sensor	22	E900-187-01
Top Cover Assy		E900-018-01
Tractor Drive Assembly	23	E900-017-01
Tractor Drive Belts	24	E900-219-00
Transformer	25	E900-159-00
Upper Blade	26	E900-013-01
Weight Belt		E900-011-01
Weight Belt Tie Bar		E900-063-00

NOTE: All Wiring Harnesses carry the Better Packages Part Number, with corresponding identification on the Main Controller Board. All harnesses may be ordered by part number.

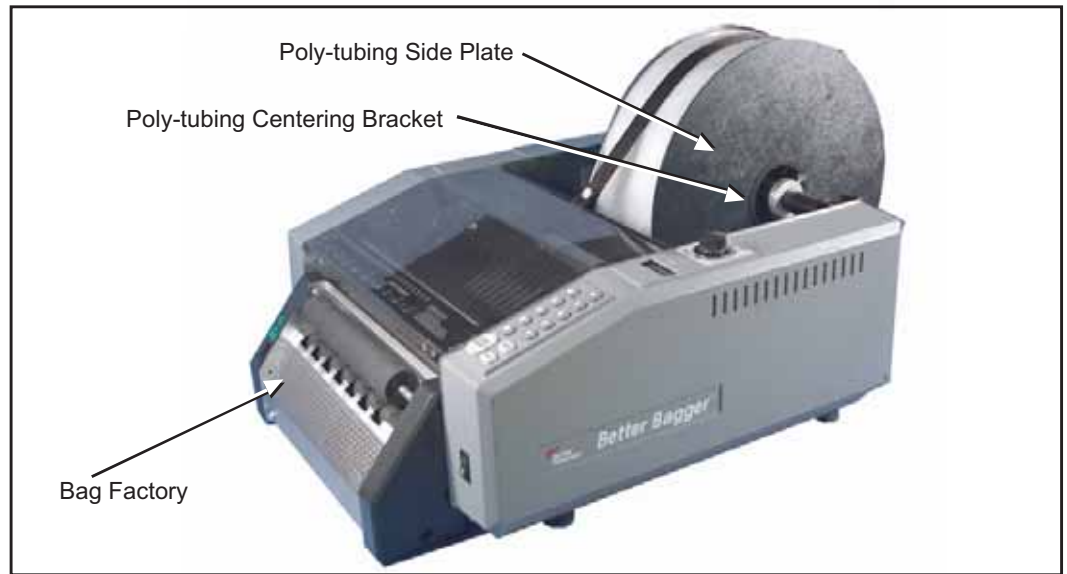

**FIGURE 1: Part identification, external**

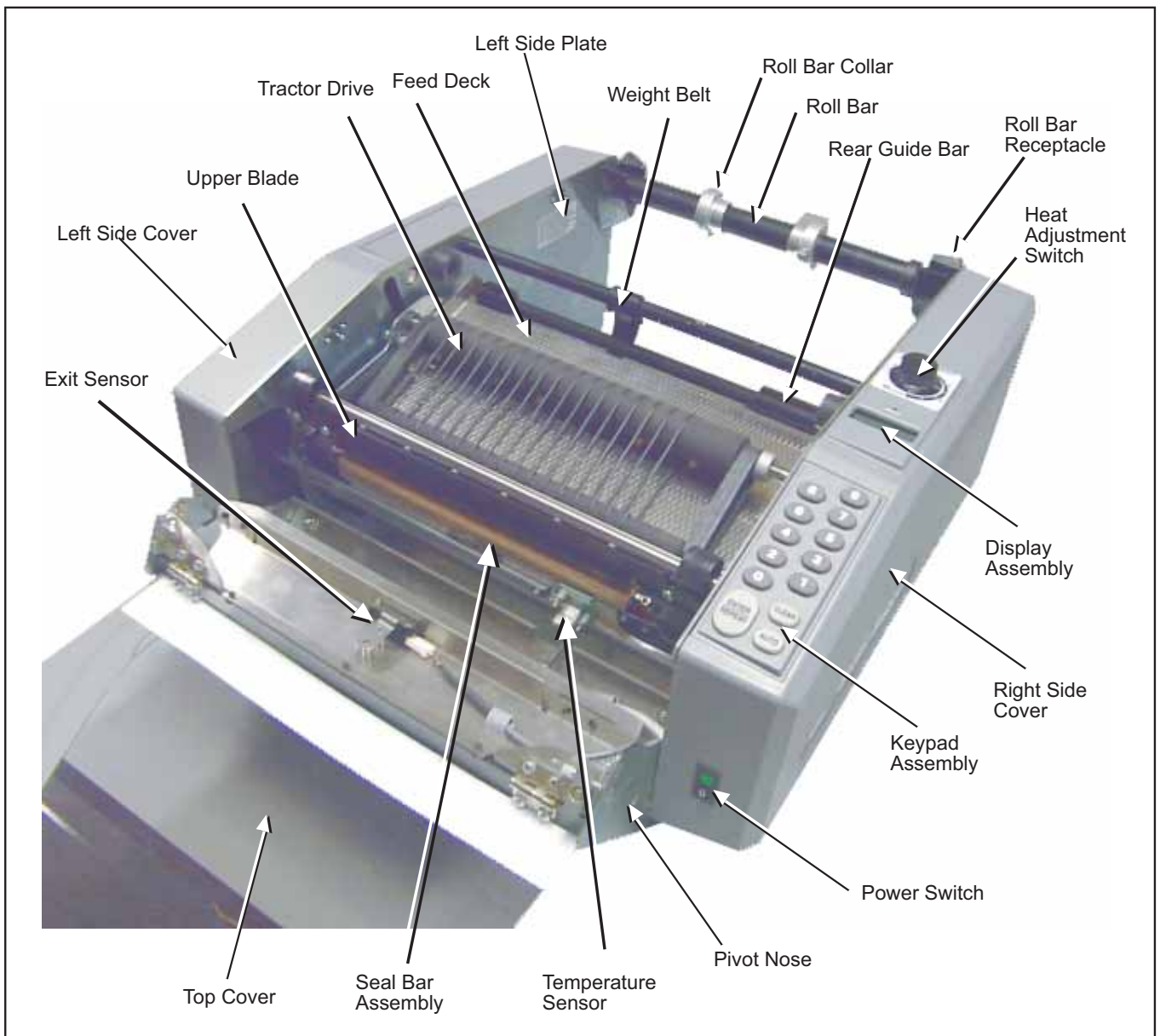

**FIGURE 2: Part identification, external and Front**

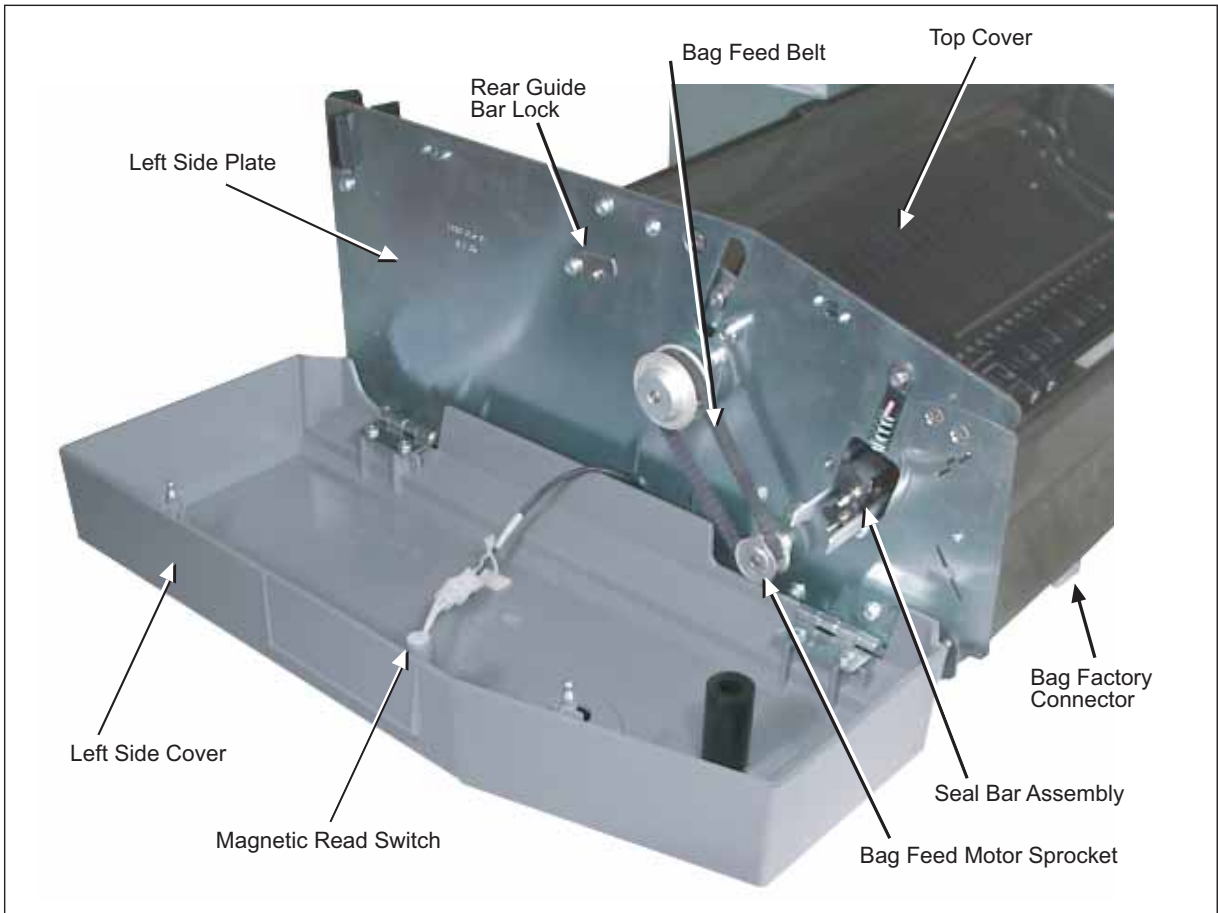

**FIGURE 3: Part identification, Left Side**

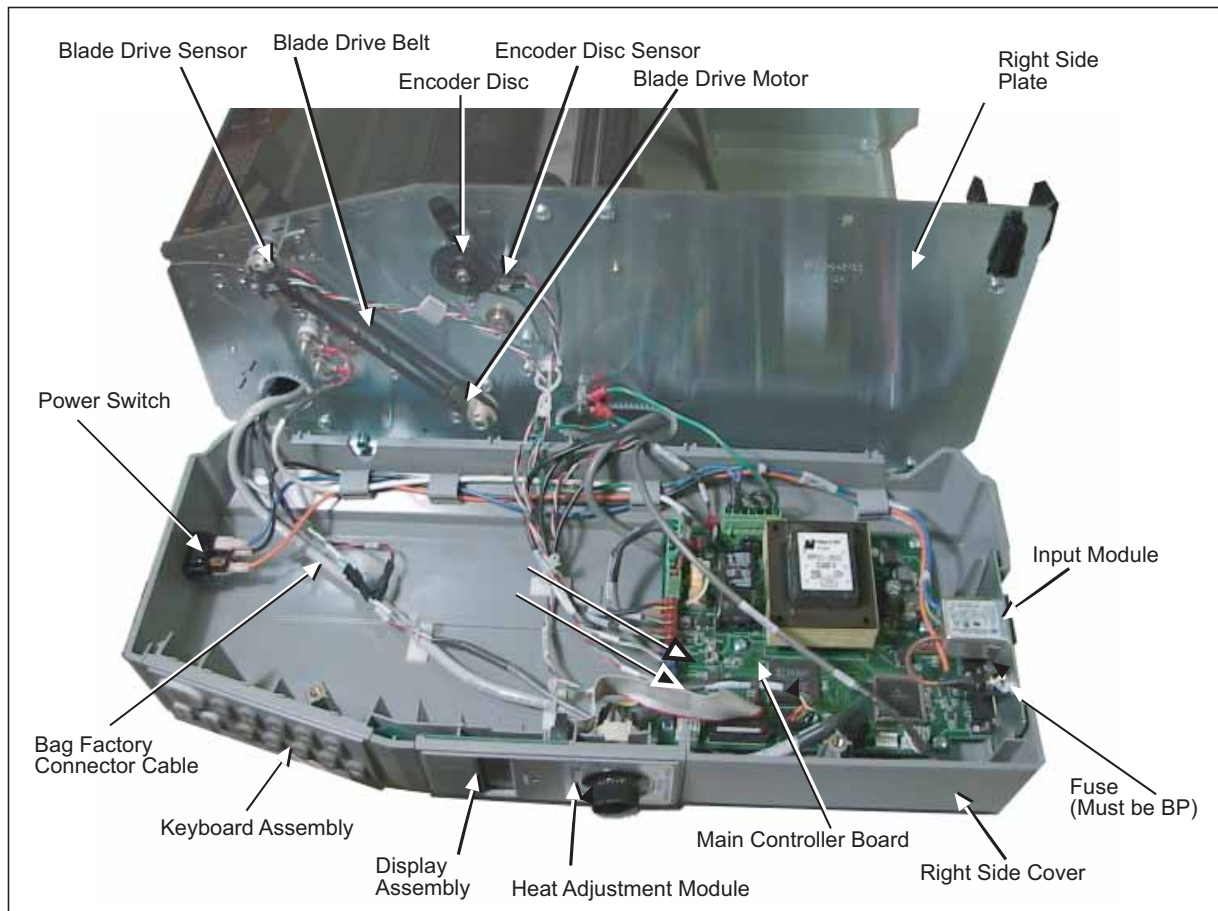

**FIGURE 4: Part identification, Right Side**

# 1. Bag Drive Roller

1. Remove the Tractor Drive Assembly, Rear Guide Bar, and Feed Deck as described elsewhere. (No.s 24 & 19)
2. Open Left Side Cover, and remove two screws in front hinge to gain tool access.
3. Loosen 4 screws of Bag Drive Motor mount to allow slack in belt. (figure 7)
4. Remove the belt from the Bag Drive Roller (larger) pulley. Loosen the 2 set screws and remove the pulley. (figure 7)
5. Remove the 2 screws fastening the left bearing plate to the left side plate (figure 8) and remove the bracket.
6. Work the roller assembly left through the hole in the left side plate and then remove it to the right.

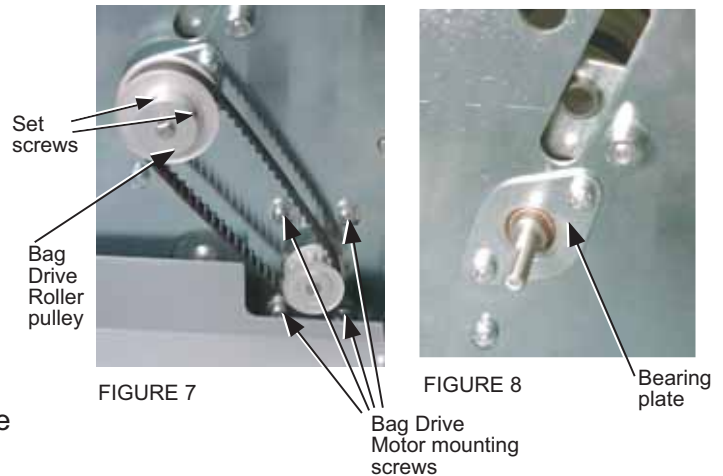

# 2. Bag Factory Connector

1. Unfasten Right Side Cover, disconnect Bag Factory cable (J302) from Main Controller Board and free cable from clips.
2. Set machine up on its rear to gain access to the Bag Factory Connector bracket..
3. Remove the four screws fastening the connector bracket. (figure 9) Slide bracket slightly to right and remove entire cable assembly from the machine.
4. Snap out the connector bracket.
5. Replace new Bag Factory Connector in reverse order.

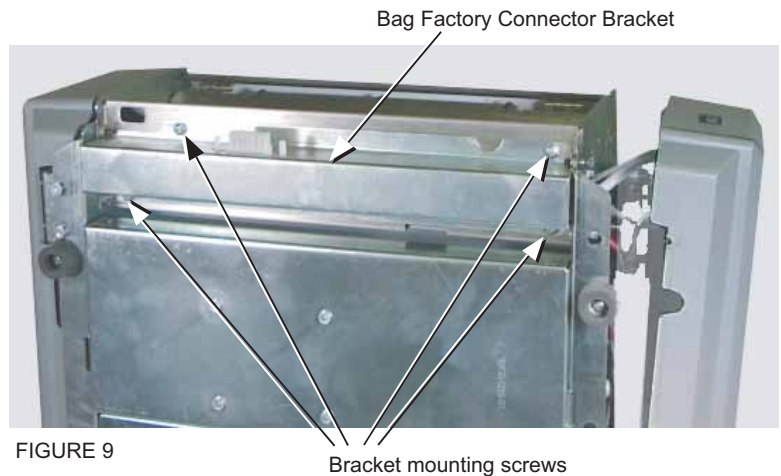

# 3. Bag Feed Belt

1. Open Left Side Cover, and remove two screws in front hinge to gain tool access.
2. Loosen 4 screws of Bag Drive Motor mount to allow slack in belt. (figure 10)
3. Remove the belt and replace.
4. Tighten 4 motor mount screws so belt has 1/4" play.

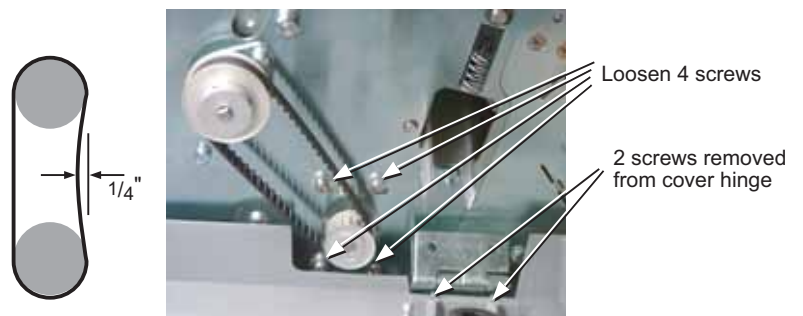

# 4. Bag Feed Motor

1. Remove the Tractor Drive Assembly, Rear Guide Bar, Feed Deck and Bag Feed Roller assembly as described elsewhere. (No.s 24,19 & 1)
2. Open Left Side Cover, and remove two screws in front hinge to gain tool access.
3. Loosen 4 screws of bag drive motor mount to allow slack in belt and remove belt.
3. Remove the bag feed motor sprocket.
4. Remove the 4 motor mount screws. (figure 11)
5. Undo the cable connector and work the motor out of the machine to the top.

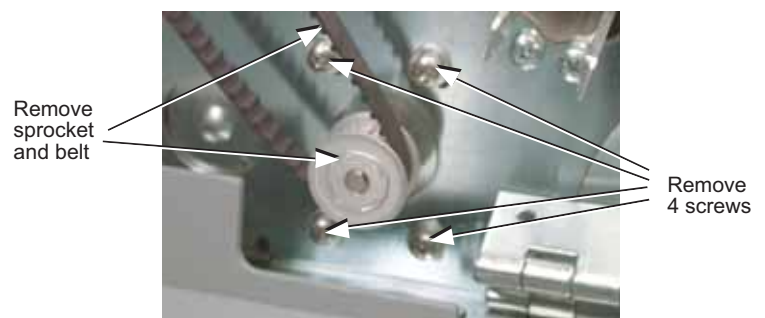
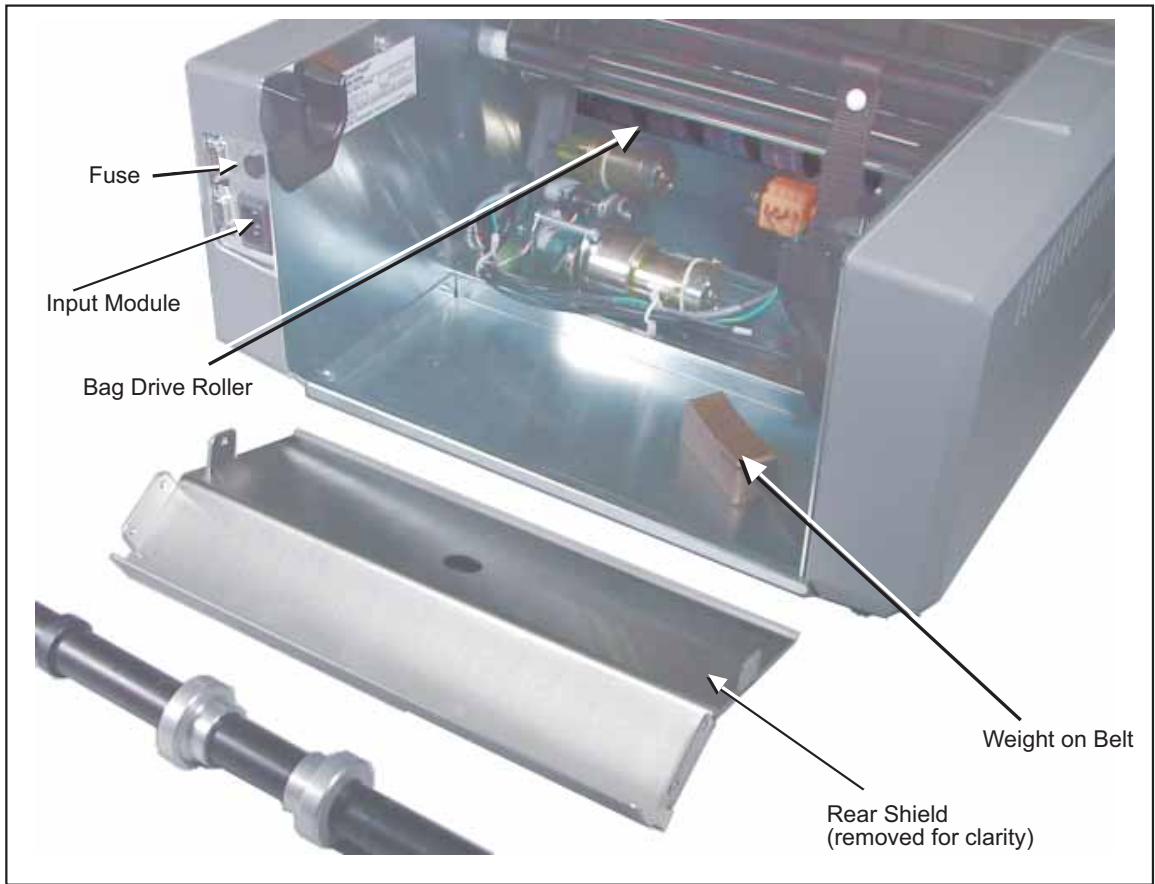
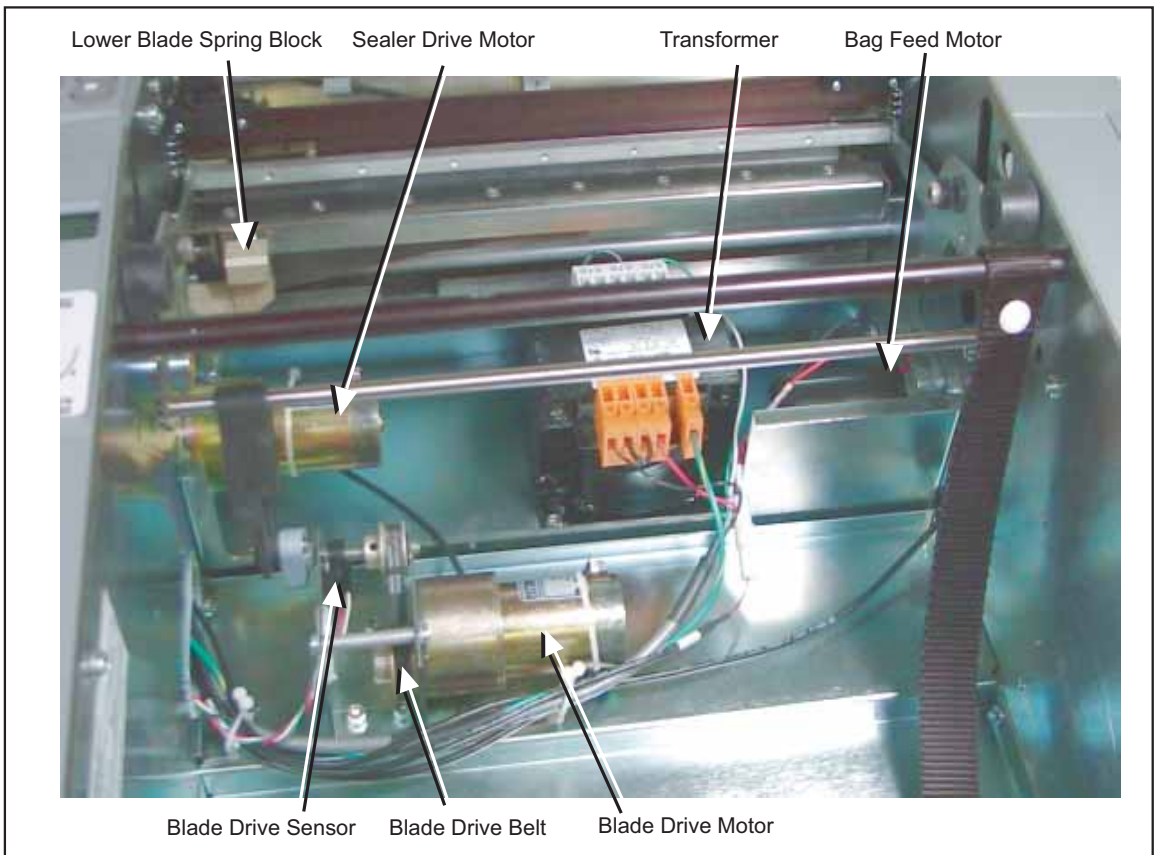

FIGURE 11



**FIGURE 5: Part identification, Rear**



**FIGURE 6: Part identification, Rear Internal**

## 5. Blade Drive Motor

1. Remove the Rear Shield (figure 5) to gain access to the Blade Drive Motor Assembly, and the Right Side Cover to access the wiring harness.
2. Detach Blade Drive Motor cable (J402) from Main Controller Board and free from clips.
3. Remove 2 knurled screws mounting the motor. (This is best achieved by extending a long allen wrench through the large cable access hole in the right side panel and the appropriate access holes in the motor mount bracket.) see figure 13
4. Remove the motor (pulley attached) to the rear.

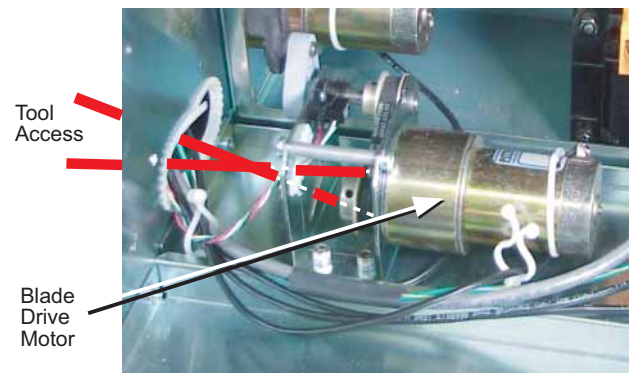

FIGURE 13

## 6. Blade Drive Sensor

1. Detach Blade Drive Sensor wiring harness (J307) from the Main Controller Board and free from clips.
2. Remove the Blade Drive Motor as described above, (No. 6) allowing access to the lower mounting screw of the Blade Drive Sensor.
3. Remove the 2 mounting screws and remove the Blade Drive Sensor. (figure 14)

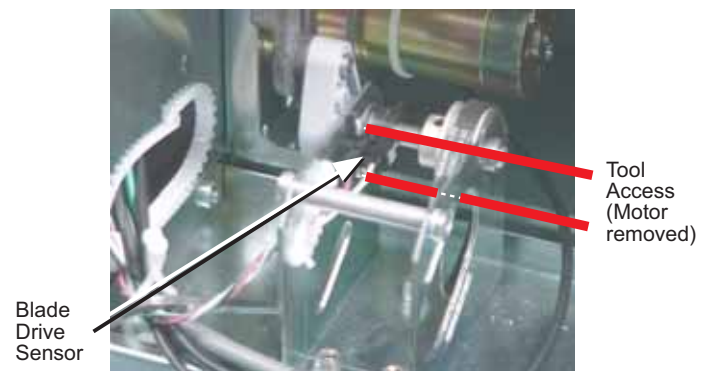

FIGURE 14

## 7. Display Assembly

1. Follow steps 1 to 3 for the Heat Adjustment Switch, described below. (No. 13)
2. Remove Keypad and Bezel by sliding up and out.
3. Disconnect ribbon connector (J301) to Display Board.
4. Lift Display Assembly from cover and disconnect Keypad membrane.
5. Replace in reverse order.

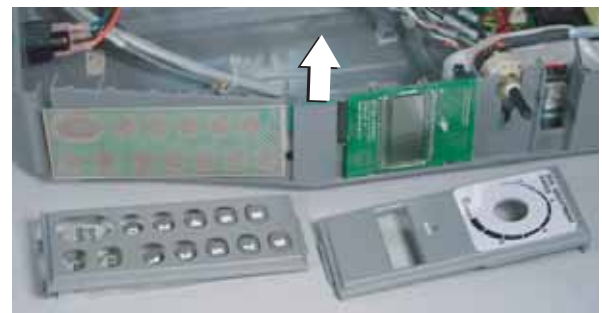

FIGURE 15

## 8. Encoder Disc

1. Remove the Encoder Disc by depressing the protruding snap bar on the disc and sliding the disc off of the shaft.
2. Replacement disc will "snap" home in position.

## 9. Encoder Disc Sensor

1. Remove the Encoder Disc Sensor by removing the 2 mounting screws and detaching the wiring harness (J305) from the Main Controller Board.

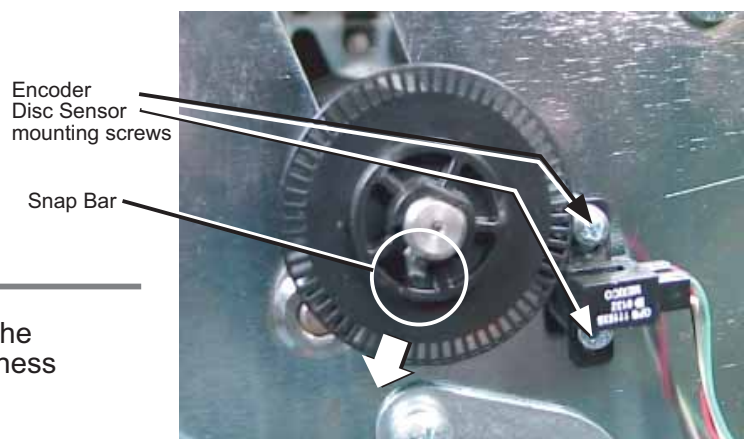

FIGURE 16

## 10. Exit Sensor

1. Open the "Pivot Nose" by releasing the 2 spring latches at both ends of the unit and rotating unit forward. (Shown in figure 2)
2. Detach the Exit Sensor cable (J303) from the main controller board and free from clips.
3. The Exit Sensor will snap off of the 2 cross-cut pins.

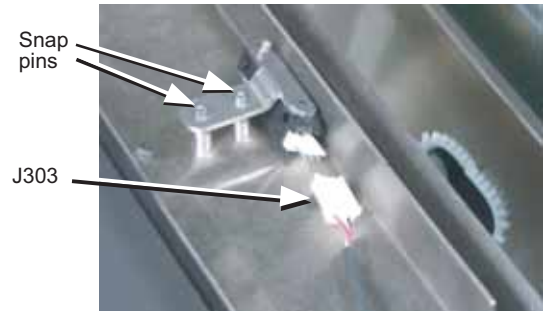

FIGURE 17

## 11. Feed Deck

The Feed Deck is removed by sliding it out towards the rear of the machine after removal of the Rear Guide Bar. See "Rear Guide Bar and Feed Deck", below. (No. 19)

## 12. Heat Adjustment Switch

1. Open Right Side Cover by removing 2 mounting screws.
2. Remove knob by loosening the set screw.
3. Loosen the 1/2" nut on the switch shaft.
4. Slide Heat/Display Bezel and Keypad Assembly up in their slots far enough to remove the Switch.
5. Detach Heat Adjustment Switch cable (J306) from the Main Controller Board.
6. Replace new switch with locator pin on switch at the bottom of the mounting slot.

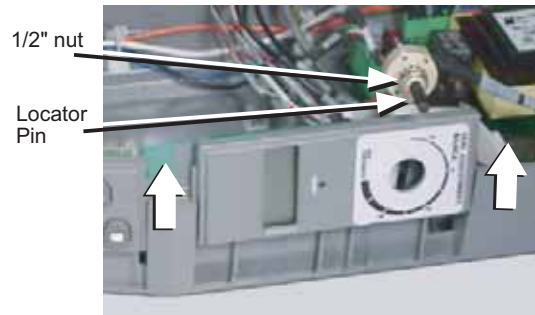

FIGURE 18

## 13. Input Module

1. Open Right Side Cover by removing 2 mounting screws.
2. Remove 6 screws fastening Main Controller Board.
3. Slide Main Controller Board away from Input Module so that the Input Module may be lifted from cover.
4. Detach wiring harness (J601) from Main Controller Board and Power Switch.
5. Replace Input Module in reverse order.
6. Be sure that wires are reconnected to the Power Switch properly upon replacement. (see figure 23)

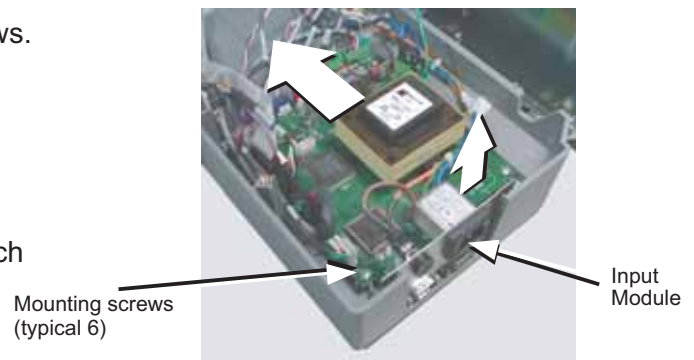

FIGURE 19

## 14. Keypad Assembly

1. Follow steps 1 to 3 for the Heat Adjustment Switch, above. (No. 13)
2. Remove Keypad Bezel and Keypad by sliding up and out.
3. Lift Display Assembly far enough to disconnect Keypad Membrane from Display Board.
4. Replace in reverse order.

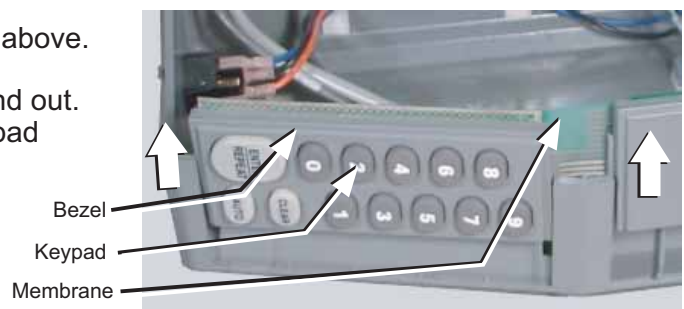

FIGURE 20

## 15. Lower Blade

1. Remove the rear guide bar (No. 19) and slide the Feed Deck out towards the rear, exposing the Lower Blade assembly.
2. Remove the top screw of the spring block and pivot the spring block back, allowing the Lower Blade assembly to pivot.
3. Remove the 4 clips on the Lower Blade shaft, and slide the shaft out of machine to the right, allowing removal of the Lower Blade and bracket.
4. Remove the 8 blade mounting fasteners and replace the Lower Blade. (figure 22)
5. Replace the assembly and spring block with the spring bearing on the back of the Lower Blade bracket.  
**Note:** The right end of the shaft has more space between the end of the shaft and the clip. (figure 22)

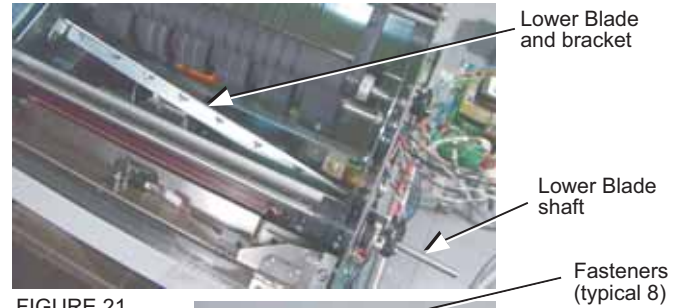

FIGURE 21

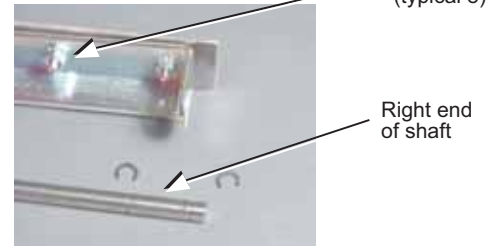

FIGURE 22

## 16. Main Controller Board

1. Open Right Side Cover by removing 2 mounting screws.
2. Remove 6 screws fastening main controller board.
3. Detach all connectors.
4. Replace in reverse order, locating connectors by numbers on both the board and the various wiring harnesses.

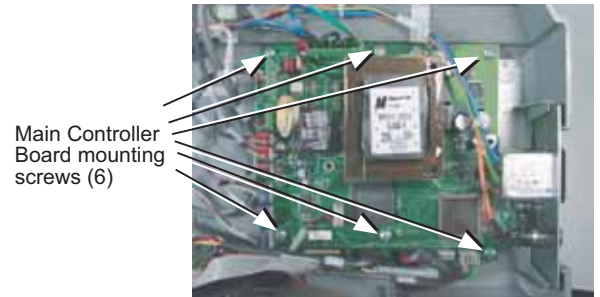

FIGURE 23

## 17. Power Switch

1. Open Right Side Cover by removing 2 mounting screws.
2. Detach wires clipped to switch.
3. Snap out Power Switch.
4. Snap in new switch and reattach wires, ensuring that the color coded wires are in the correct position. (figure 24)

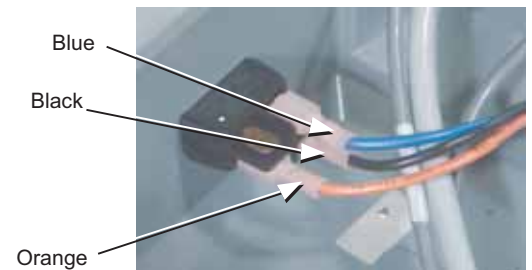

FIGURE 24

## 18. Rear Guide Bar and Feed Deck

1. Loosen the screw fastening the Rear Guide Bar lock.
2. Pivot the Rear Guide Bar lock to the left to disengage from shaft.
3. Slide Rear Guide Bar shaft out of machine, freeing Rear Guide Bar and bushings to be lifted out.
3. Feed Deck is now free to be slid out towards the rear of the machine.

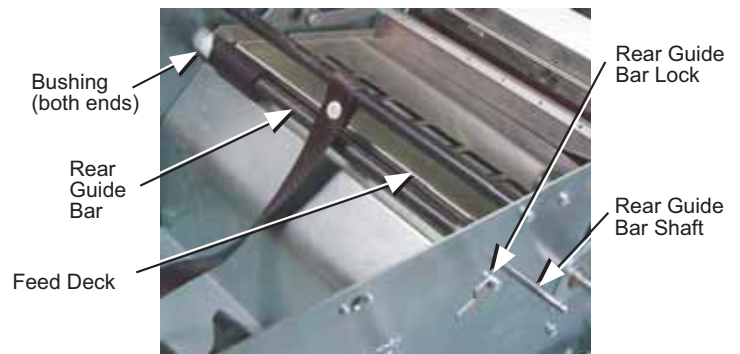

FIGURE 25

## 20. Sealer Drive Belt

1. Remove the Sealer Drive Sensor bracket assembly by removing 2 screws on inside of Right Side Plate. **Note:** Do not remove sensor from bracket, as this will require readjustment.
2. Loosen 2 screws of Blade Drive Motor mount to allow slack in belt.
3. Remove the Blade Drive Belt and replace.
4. Re-tighten 2 motor mount screws so the belt 1/4" play, and reattach sensor bracket assembly.

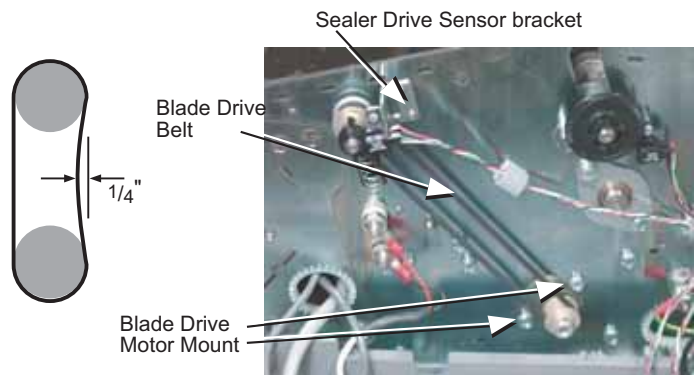

FIGURE 26

## 21. Sealer Drive Motor

1. Remove the rear shield (figure 5) to gain access to the Sealer Drive Motor, and open the Right Side Cover to access the wiring harness.
2. Detach Sealer Drive Motor cable (J401) from main controller board and free from clips.
3. Remove 2 screws mounting Sealer Drive Motor.
4. Work the unit out the rear of machine.
5. Replace in reverse order.

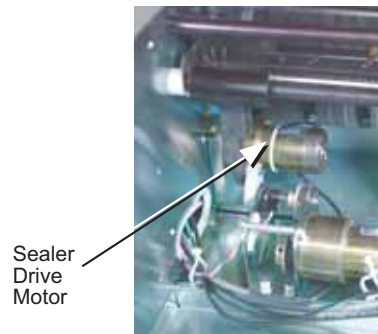

FIGURE 27

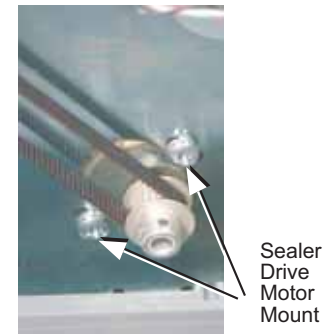

FIGURE 28

## 22. Temperature Sensor

1. Open the "Pivot Nose" by releasing the 2 spring latches at both ends of the unit and rotating forward. (figure 2)
2. Detach the Temperature Sensor cable (J309) from the Temperature Sensor assembly.
3. Remove 2 screws fastening Temperature Sensor bracket.
4. Make sure that the sensor chip on the circuit board is in contact with the heater bar when installed.

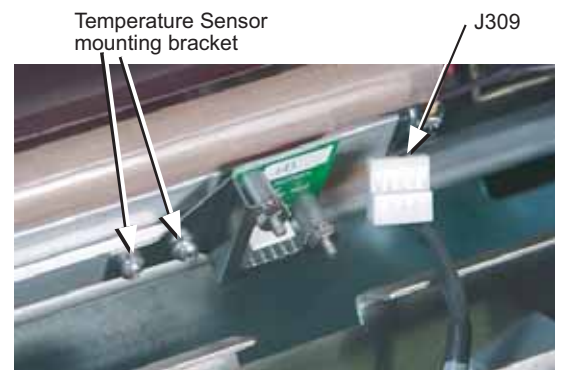

FIGURE 29

## 23. Tractor Drive Assembly

1. Open the Right Side Cover and remove the Encoder Disc as described previously. (No. 9)
2. Remove the clip from the left end of the smaller roller shaft.
3. Remove the 2 e-rings from both ends of the larger roller shaft of the tractor drive assembly.
4. Lifting the smaller (front) shaft slightly to clear the blade yoke, work assembly to the right to free left end of large shaft.
5. Remove the left connecting arm. (Required for side to side play.)
6. Work assembly back to the left through slot in left side frame, freeing right end of large roller shaft and allowing tractor drive assembly to be lifted from machine.

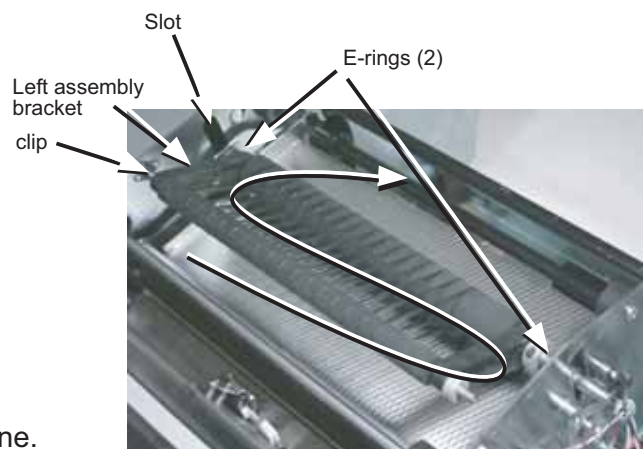
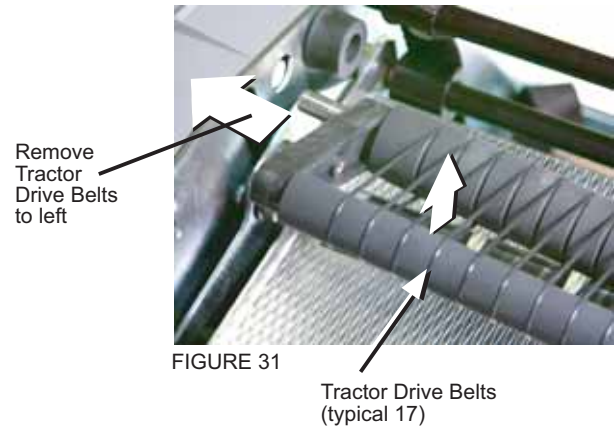

FIGURE 30

## 24. Tractor Drive Belts

1. Remove the 2 e-rings from both ends of the larger roller shaft of the Tractor Drive Assembly. (See figure 30)
2. Lifting the smaller (front) shaft slightly to clear bracket, work assembly to the right to free left end of large shaft.
3. Remove and replace belts as necessary, fitting new belts into grooves in both rollers.
4. Insert left end of large roller shaft back into bushing and replace both e-rings.



## 25. Transformer

1. Remove Rear Shield. (figure 5)
2. Remove the Tractor Drive Assembly, Rear Guide Bar, Feed Deck and Bag Drive Roller as described above. (No.s 24, 19 & 1)
3. Detach Transformer wiring harness (J500) from Main Controller Board
4. Remove 4 screws mounting Transformer.
5. Work the Transformer out the rear of machine.

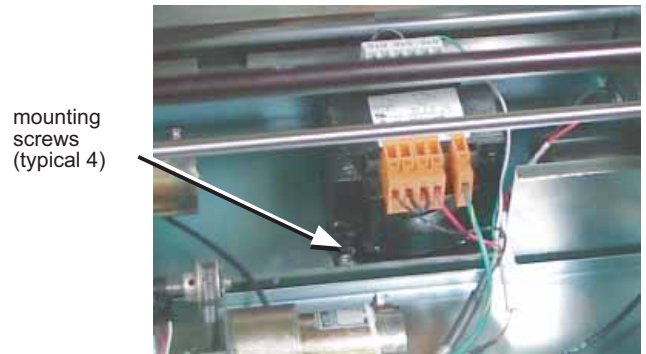

## 26. Upper Blade

1. Open the "Pivot Nose" by releasing the 2 spring latches at both ends of the unit and rotating unit forward. (Shown in figure 2)
2. Grasp the Upper Blade mounting bar (behind blade) and lift to rotate mechanism to its highest position.
3. Remove the 7 Upper Blade mounting screws and replace blade.

